

CLIP PINCE BORD DE TOLE

6 rue Nationale 92100 BOULOGNE-BILLANCOURT

Tél : 01 46 21 05 32

Fax : 01 46 21 00 76

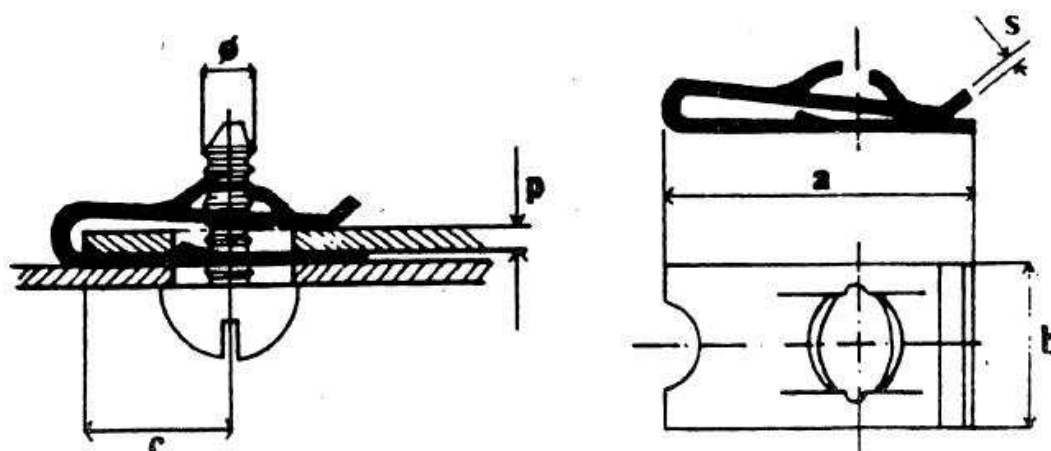

MATIERE : ACIER RESSORT

POUR ASSEMBLAGE PAR VIS A TOLES

Ø DE VIS	Formes *	Epaisseur de tôle p	Références	Dimensions			
				a	b	c	s
4.2	N	0.6-1.4	49/U42-109	25.6	12	14	0.60
	G	2.5-3.2	49/U42-532	16	12	9.2	0.60
	B	2.0-3.0	49/U42-230	17	11	8.4	0.60
	H	2.5-3.0	49/U42-503	11.8	9	6.2	0.60
	G	2.5-3.2	49/U42-530	16.3	10	8.5	0.60
	G	2.5-3.5	49/U42-253	16	10	10	0.60
	C	4.0-6.0	49/U42-460	20	10	11	0.60
	C	3.8-4.2	49/U42-342	16	11	8.4	0.60
	C	3.0-5.0	49/U42-350	16	11	8.4	0.60
B	3.5-4.0	49/U42-400	23.5	11	15.8	0.70	
4.8	E	3.5	49/U48-350	17	16	10	0.50
	E	0.3-1.5	49/U48-031	17	16	10	0.50
	H	2.0	49/U48-200	12	10	6	0.60
	A	0.3-2.0	49/U48-032	15	12	7.8	0.70
	B	0.3-2.8	49/U48-328	29.2	12	22.1	0.60
	G	0.3-2.8	49/U48-382	19.5	12	8.2	0.70
	D	1.0-2.2	49/U48-122	12.5	16	5.8	0.70
	M	1.0-3.5	49/U48-135	17	11	9	0.50
	L	3.6	49/U48-360	17	11	9	1.00
G	2.5-3.2	49/U48-253	16	12	9.2	0.70	
5.5	B	0.3-3.2	49/U55-033	26	15	13.7	0.80
6.3	G	5.6	49/U63-560	21	16	14	0.60

* voir fiche technique référence 49/FORMES