

CLIP PINCE BORD DE TOLE

6 rue Nationale 92100 BOULOGNE-BILLANCOURT

Tél : 01 46 21 05 32

Fax : 01 46 21 00 76

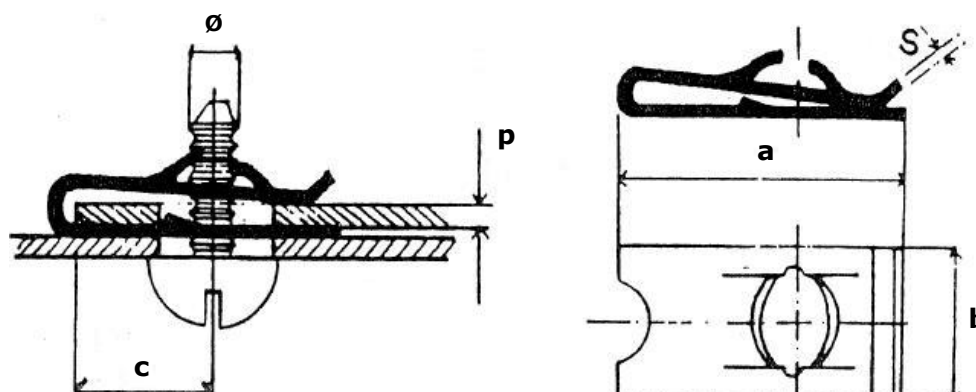

MATIERE : ACIER RESSORT

POUR ASSEMBLAGE PAR VIS A TOLES

Ø DE VIS	Formes *	Epaisseur de tôle p	Références	Dimensions			
				a	b	c	s
2.8	B	0.3-1.5	49/U29-031	10.5	8	5	0.50
	I	1.7	49/U29-170	10	10	4.6	0.45
	C	3.5-4.0	49/U29-354	10.5	7.5	5	0.50
3.5	B	1.6-2.5	49/U35-250	11.2	9	6.2	0.50
	B	0.3-1.5	49/U35-031	11.2	9	6.2	0.50
	A	0.3-2.0	49/U35-319	15	12	8.5	0.50
	B	0.3-2.0	49/U35-320	16.3	11	8.7	0.60
	B	0.3-1.5	49/U35-061	16	11	8.4	0.50
	B	1.0-2.0	49/U35-120	12	12	6.9	0.60
	A	1.5-2.5	49/U35-132	14.5	12	7.9	0.60
	B	1.5-2.5	49/U35-172	14.5	9	8	0.50
	H	2.5-3.0	49/U35-503	11.8	9	6.2	0.50
	G	2.5-3.5	49/U35-253	16	10	10	0.60
	B	1.0-1.5	49/U35-223	16	11	8.5	0.50
G	2.5-3.0	49/U35-300	12	9	5.5	0.60	
3.9	A-B	0.3-2.0	49/U39-032	14.5	12	7.9	0.50
	A	1.0-1.5	49/U39-115	11	9	5	0.60
4.2	G	2.5-3.0	49/U42-300	12	9	5.5	0.60
	B	1.5-2.0	49/U42-152	16	11	8.4	0.60
	B	0.3-1.2	49/U42-031	11.2	9	6.2	0.50
	A	0.3-2.0	49/U42-032	14.5	12	7.9	0.60
	B	0.3-2.0	49/U42-061	16	11	8.4	0.50
	B	0.3-2.2	49/U42-322	20	12	7.5	0.70
	B	0.3-2.5	49/U42-325	24	11	16	0.60
	H	1.8	49/U42-180	10.5	9	5.4	0.60
	B	1.8-2.8	49/U42-182	16	11	8.4	0.60
	A	2.2-2.8	49/U42-228	15	12	8	0.60
	C	2.5-3.5	49/U42-235	13.2	9	6	0.60
C	3.8-4.2	49/U42-536	13.2	9	6	0.60	

* voir fiche technique référence 49/FORMES